

Enjoy Your

Captiva Designs

USE AND CARE GUIDE

E02GR004

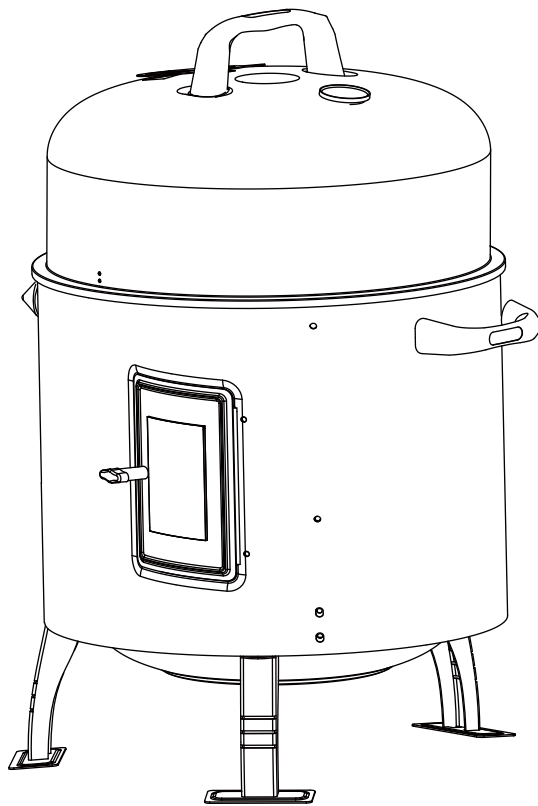

Assembly, Care And Use Instructions
Read Carefully Important: Retain These
Instructions For Future Reference.



This appliance is for Household use only.
This is not a commercial appliance.

THANK YOU

We appreciate the trust and confidence you have placed in Captiva Designs through the purchase of our product. We strive to continually create quality products designed to enhance your home. Visit us online to see our full line of products available for your home improvement needs. Thank you for choosing Captiva Designs!

Table of Contents

Safety Information	2	Curing your smoker	11-12
Warning	3	General Operating Instructions	12-15
Preparation	4	Cleaning and Maintenance	16
Components	5-6	Environmental Protection & Disposal	16
Assembly Instructions	7-10	Warranty	17

Safety Information

Assembler/Installer

This instruction manual contains important information necessary for the proper assembly and safe use of this appliance. Read and follow all warnings and instructions before assembling and using this appliance.

Leave these instructions with the consumer.

Consumer/User

Follow all warnings and instructions when using this appliance. Keep these instructions for future reference.

Proper Utilisation

The smoker may only be used for preparing suitable foods. All requirements of this assembly and operation manual must be complied with. Only for private domestic use!

Warning



Prop 65 Warning

This product can expose you to chemicals including Chromium (hexavalent compounds), which are known to the State of California to cause cancer and birth defects or other reproductive harm. For more information visit www.P65Warnings.ca.gov.

Warning

WARNING:

Risk of burning!

- Make sure that the smoker is standing on a flat and fireproof surface that is not made of glass or plastic.

WARNING:

This smoker will become very hot, do not move it during operation!

- Always wear smoker gloves when grilling or adjusting the vents as well as when using a chimney starter.
- When preparing food, adjusting the vents, placing charcoal and using the thermometer or lid always wear barbecue gloves.
- Grill gloves must be tested in accordance with local code.
- For grilling use only qualified barbecue charcoal or barbecue charcoal briquettes.
- Do not BBQ before the fuel has a coating of ash.
- Use grilling tongs with long, heat-resistant handles.
- Allow the smoker to cool down completely before cleaning it.

WARNING:

DANGER to children and pets!

- Never leave the hot smoker unattended.
- **WARNING! Keep children and pets away!**

WARNING:

- Do not use spirit or petrol for lighting or re-lighting!
- Never use water to extinguish the charcoal.

WARNING:

Risk of carbon monoxide poisoning!

- **Do not use indoors !**

Information for safe operation of the smoker

- The smoker must be positioned in a stable and secure surface.

Do not use in enclosed areas or on covered areas.

- Only use safe lighting materials.
- The smoker should be heated up and the fuel kept red hot at least 30 minutes before it is used for the first time.
- When smoker is in use, maintain clearance of 36" between the hot smoker and any combustible materials, such as bushes, trees, wooden decks, wooden fences, buildings, etc. Do not place hot smoker under roof overhang or in any other enclosed area.

Preparation

Before beginning assembly of product, make sure all parts are present. Compare parts with package contents list and hardware contents above. If any part is missing or damaged, do not attempt to assemble the product. Contact customer service for replacement parts.



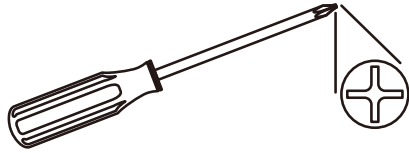

Estimated Assembly Time: 20 minutes.

Tools Required for Assembly: Wrench (not included) and Phillips Screwdriver (not included)



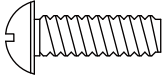
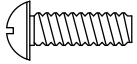
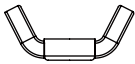
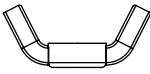

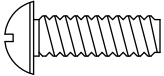
Components

Hardware Contents

Item No.	Item name	Diagram	Qty
A	M6X10 Philips Head Flange Bolt		12
B	M5X10 Philips Head Flange Bolt		2
C	M6 Wing Nut		6
D	M8 Wing Nut (pre-assembled on thermometer)		1
E	Flat Washer		6
F	Lock Washer		6
G	M6X8 Bolt		1
H	M6 Nut		1

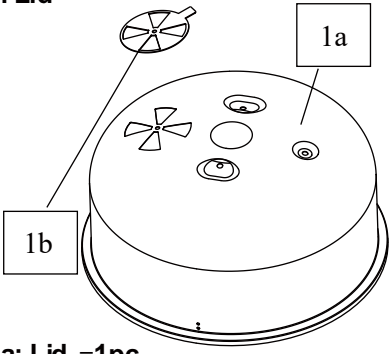
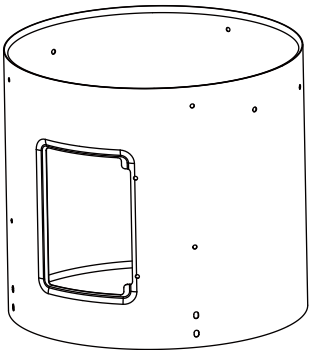
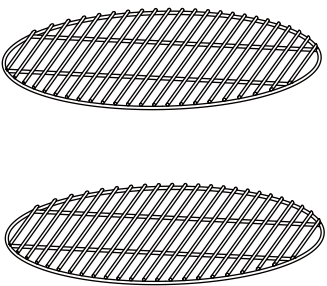
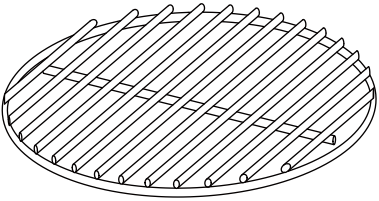
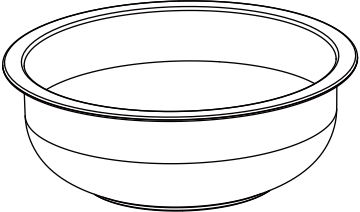
Components

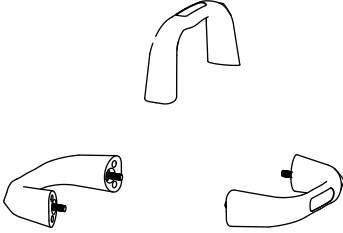
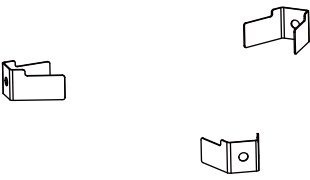
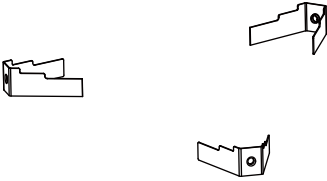
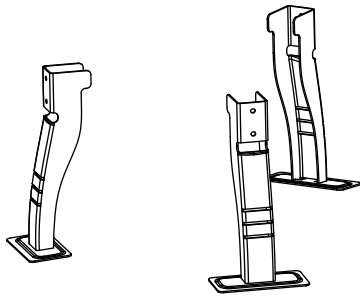
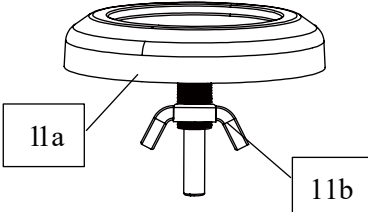
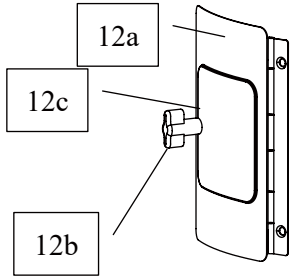
<p>1. Lid</p>  <p>1a: Lid -1pc 1b: Air vent -1pc</p>	<p>2. Body</p>  <p>Qty:1</p>	<p>3. Cooking Grate</p>  <p>Qty:2</p>
<p>4. Charcoal Grate</p>  <p>Qty:1</p>	<p>5. Charcoal Bowl</p>  <p>Qty:1</p>	<p>6. Water Bowl</p>  <p>Qty:1</p>
<p>7. Handle</p>  <p>Qty:3</p>	<p>8. Short Grate Bracket</p>  <p>Qty:3</p>	<p>9. Long Grate Bracket</p>  <p>Qty:3</p>
<p>10. Leg</p>  <p>Qty:3</p>	<p>11. Thermometer / Nut</p>  <p>11a: Thermometer - 1pc 11b: M8 Wing Nut - 1pc (Nuts pre-assembled on thermometer)</p>	<p>12. Door Assembly</p>  <p>12a: Door- 1pc 12b: Door handle - 1pc 12c: Lock plate - 1pc</p>

Components

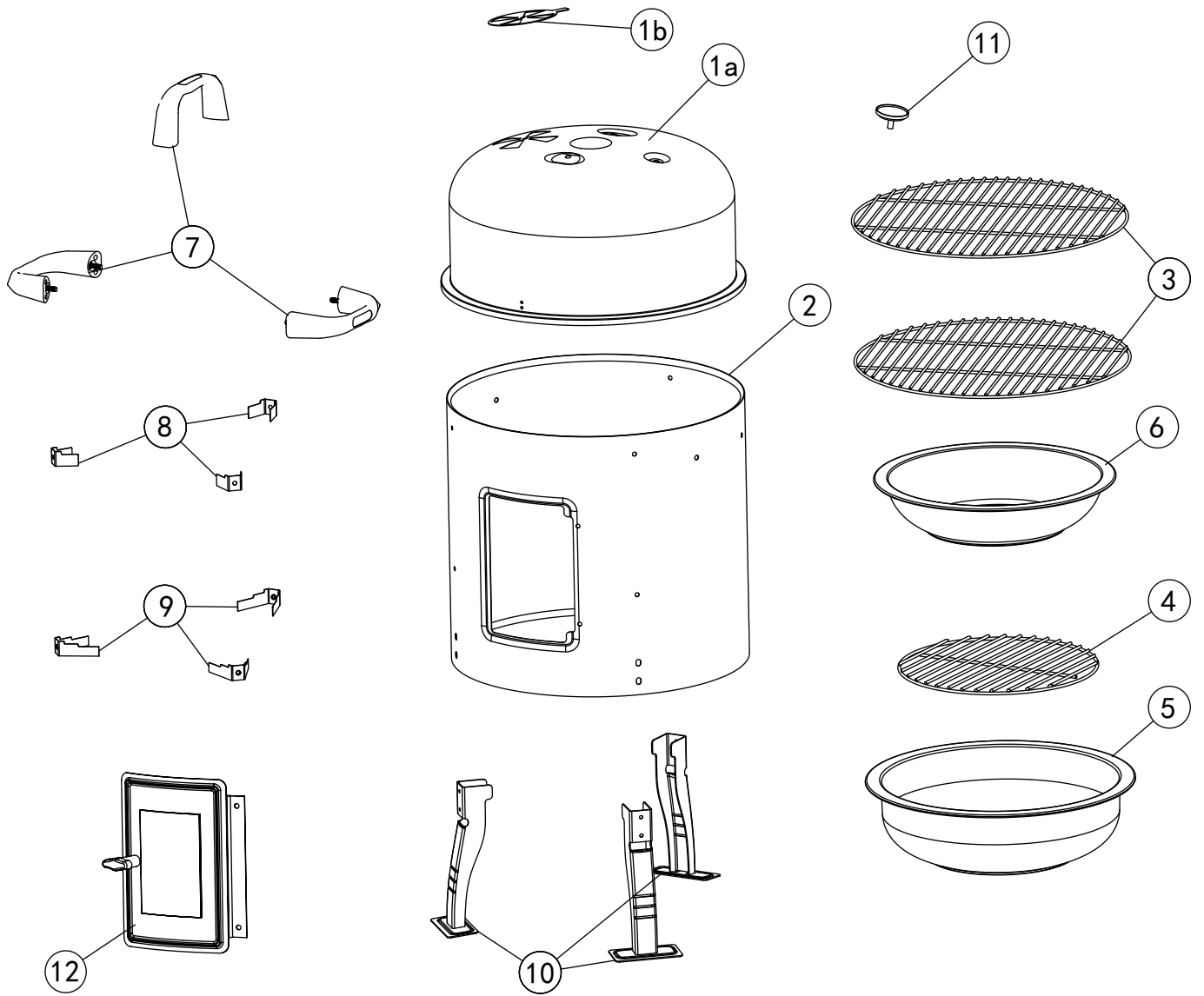

Assembly Instructions

Please read the assembly instructions carefully and follow the safety precautions. Allow sufficient time for assembly. Before starting assembly, clear an area measuring approximately two to three square meters. Remove the item from the packaging. Lay out all of the parts and any necessary tools so that they are within easy reach.

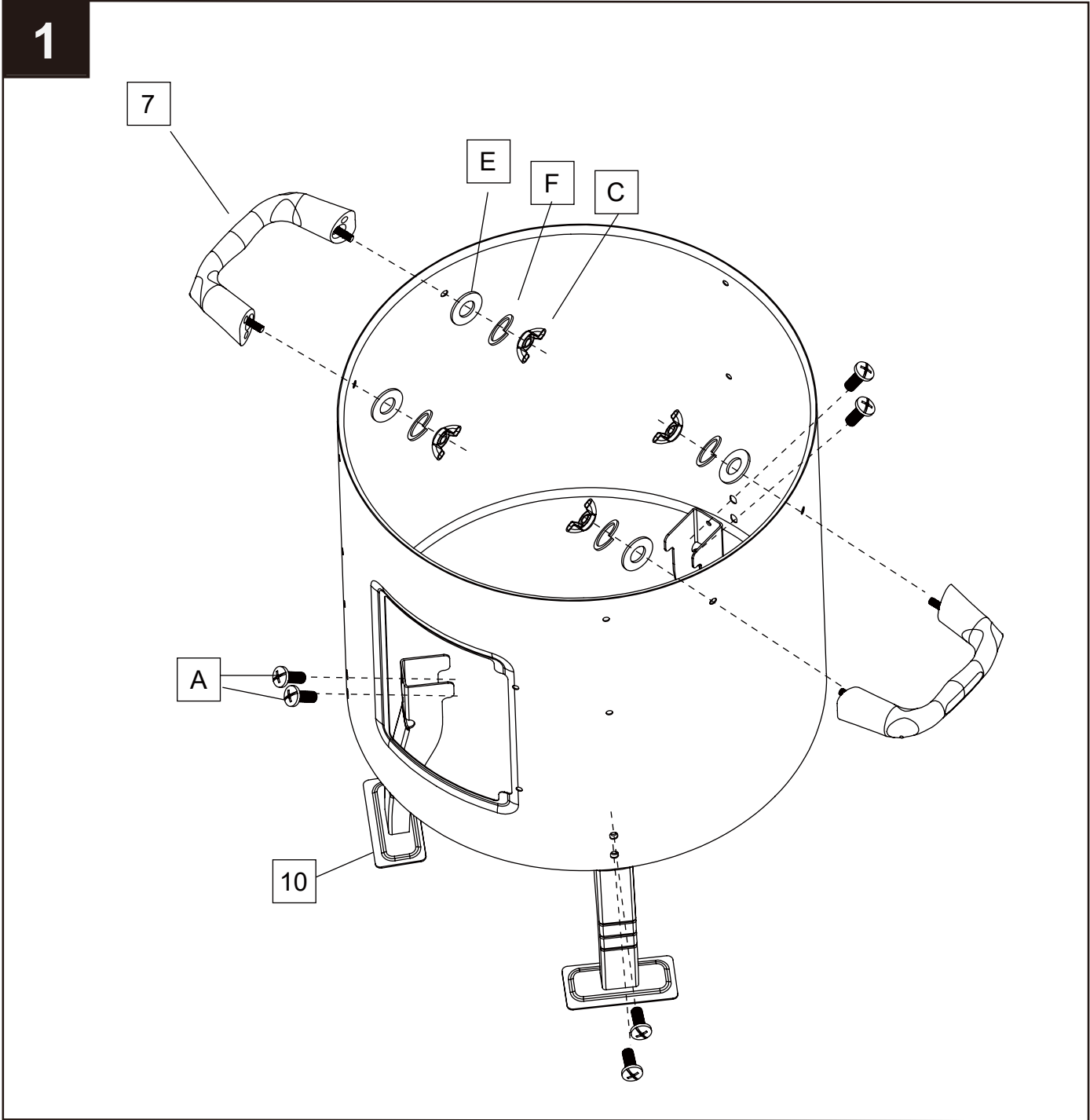

Assembly Instructions

2

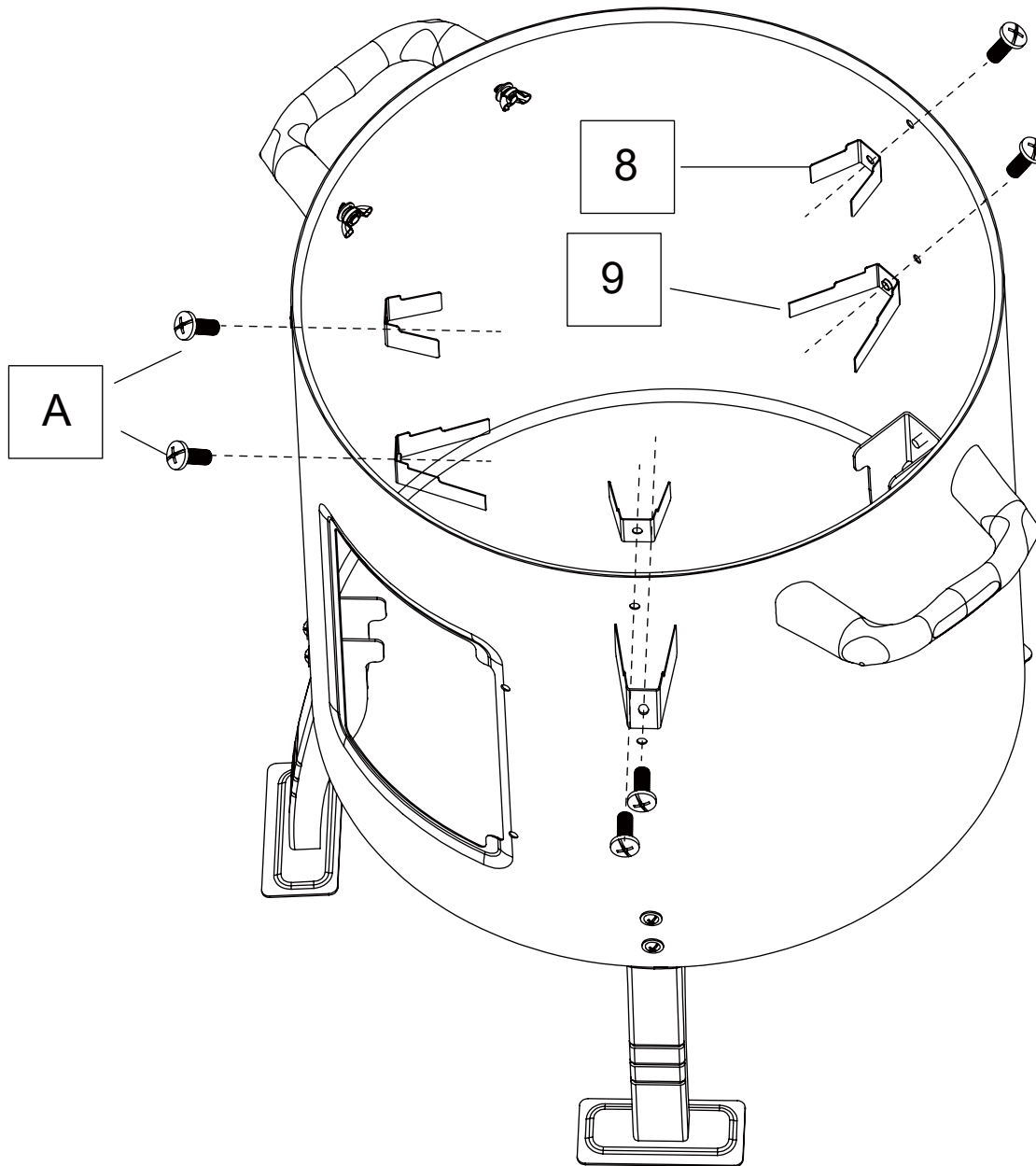

Assembly Instructions

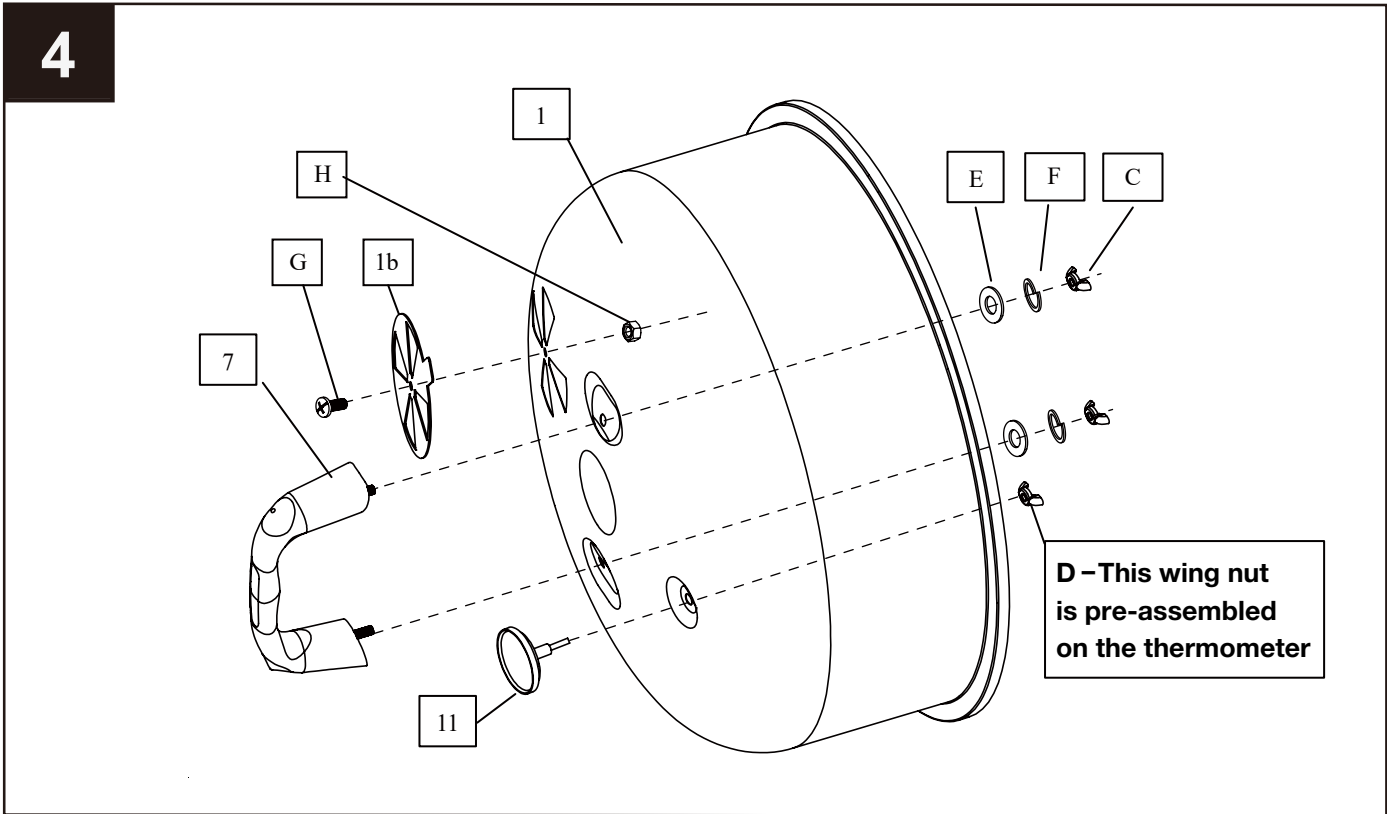
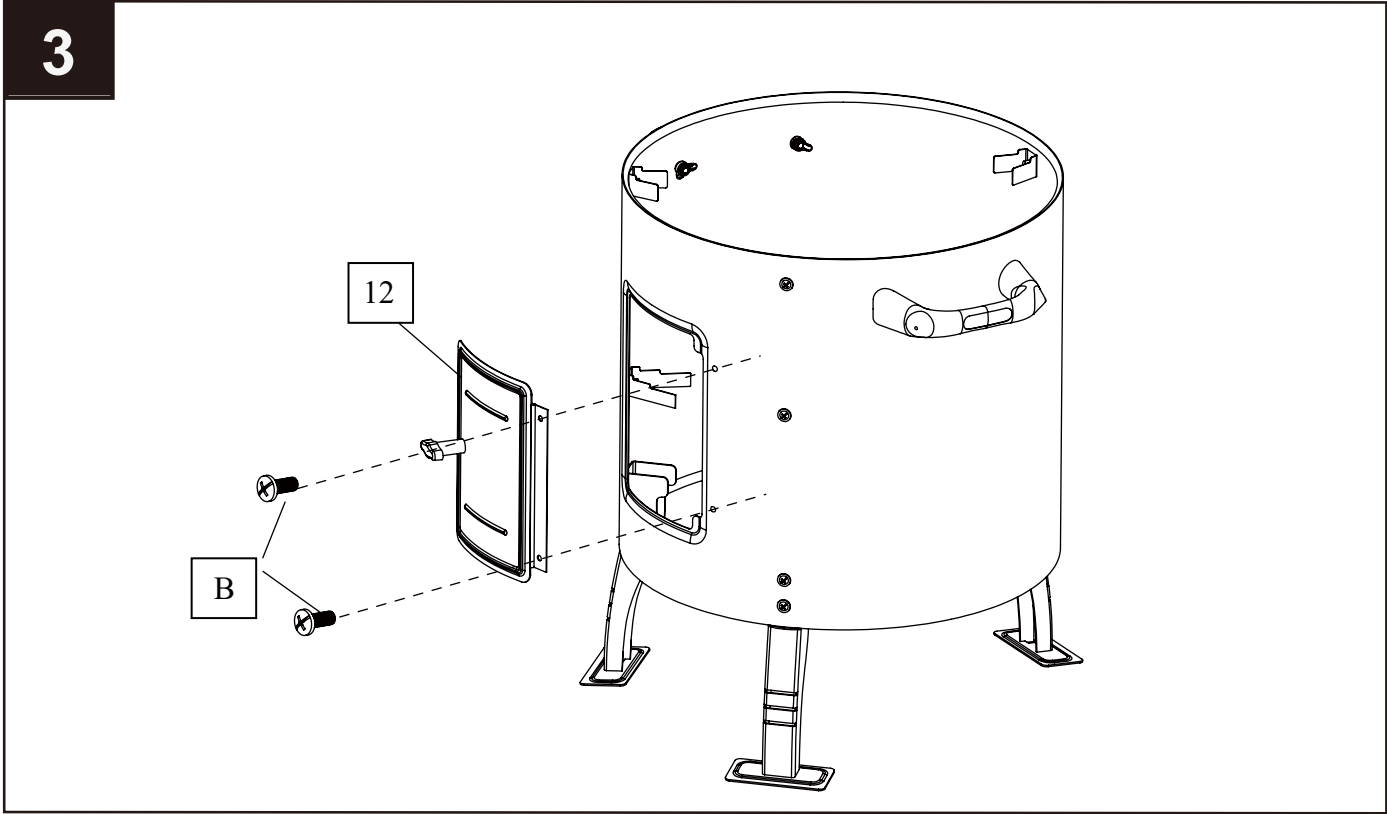

Assembly Instructions

5

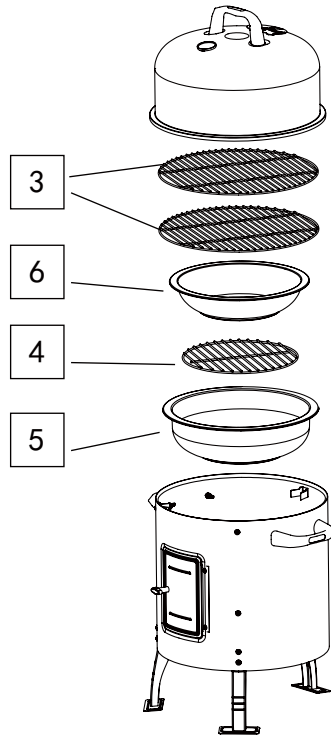

6

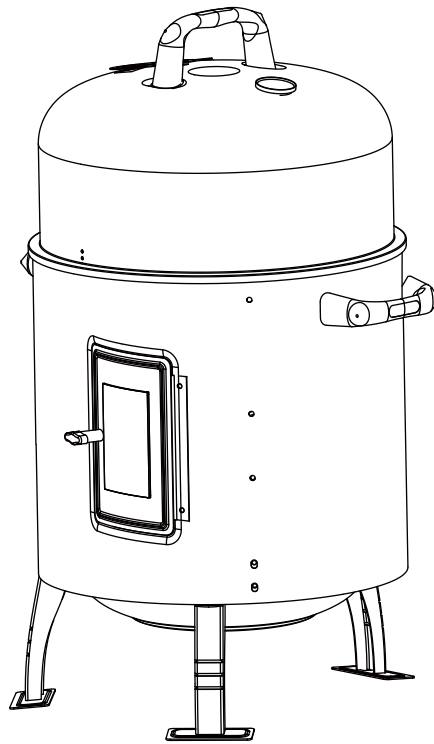

Curing Your Smoker

Prior to your first use of the smoker, follow the instructions below carefully to cure your smoker. Curing your smoker will minimize damage to the exterior finish as well as rid the smoker of paint odor that can impart unnatural flavors to the first meal prepared on the smoker.

IMPORTANT: To protect your smoker from excessive rust, the unit must be properly cured and covered at all times when not in use.

Step1

Lightly coat all interior surfaces of the smoker with vegetable oil or vegetable oil spray. Do not coat charcoal grate or inner bowl.

Step2

Follow the instructions below carefully to build a fire.

If using a Charcoal Chimney Starter, follow all manufacturer's warnings and instructions regarding the use of their product. Place charcoal on top of grate in chimney starter until full. Underneath grate place balled up paper and light with match or lighter thru holes in bottom of chimney sides. Once paper lights, fire will spread up thru charcoal until entire column is glowing red in the bottom with ash formation on top. Pick up by handle and pour lit charcoal into smoker. Start with 2.4 pounds (1.1kg) of charcoal. This should be enough charcoal to cook with, once the curing process has been completed.



NOTE:

To extend the life of your smoker, make sure that hot charcoal and wood do not touch the walls of smoker.

IF USING CHARCOAL CHIMNEY STARTER, PROCEED TO STEP 5.

If you choose to use charcoal lighting fluid, **ONLY** use charcoal lighting fluid approved for lighting charcoal. Do not use gasoline, kerosene, alcohol or other flammable materials for lighting charcoal. Follow all manufacturer's warnings and instructions regarding the use of their product. Start with 2 to 2.4 pounds (0.9 to 1.1 kg) of charcoal. This should be enough charcoal to cook with, once the curing process has been completed. Place the charcoal in the center of the charcoal grate.

Step3

Saturate charcoal with lighting fluid. With lid open, wait 2 to 3 minutes to allow lighting fluid to soak into charcoal. Store lighting fluid a safe distance from the smoker.

Step4

With smoker lid open, stand back and carefully light charcoal. Allow to burn until covered with a light ash (approximately 20 minutes).



WARNING:

Charcoal lighting fluid must be allowed to completely burn off prior to closing smoker lid (approximately 20 minutes). Failure to do this could trap fumes from charcoal lighting fluid in smoker and may result in a flash-fire or explosion when lid is opened.

Curing Your Smoker

Step5

With charcoal burning strong, close the lid. Allow the temperature to reach 225°F (107°C) on temperature gauge. Maintain this temperature for 2 hours.

Step6

Increase the temperature to 400°F(205°C) on temperature gauge. This can be achieved by adding more charcoal and / or wood . Maintain this temperature for 1 hour then allow unit to cool completely.



NOTE:

It is important that the exterior of the smoker is not scraped or rubbed during the curing process.

IMPORTANT: To protect your smoker from excessive rust, the unit must be cured periodically and covered at all times when not in use.

General Operating Instructions

Step1

Lightly coat all interior surfaces of the smoker including cooking grate with vegetable oil or vegetable oil spray. Do not coat charcoal grate or charcoal bowl.

Step2

Follow the instructions below carefully to build a fire. You may use charcoal and / or wood as fuel in the smoker .

If using a Charcoal Chimney Starter, follow all manufacturer's warnings and instructions regarding the use of their product. Place charcoal on top of grate in chimney starter until full. Underneath grate place balled up paper and light with match or lighter thru holes in bottom of chimney sides. Once paper lights, fire will spread up thru charcoal until entire column is glowing red in the bottom with ash formation on top. Pick up by handle and pour lit charcoal into smoker. Start with 2.4 pounds (1.1kg) of charcoal.



WARNING:

DO NOT use smoker without charcoal grate in place. **DO NOT** attempt to remove charcoal grate while smoker contains hot charcoal.



NOTE:

To extend the life of your smoker, make sure that hot charcoal and wood do not touch the walls of smoker.

IF USING CHARCOAL CHIMNEY STARTER, PROCEED TO STEP 5.

If you choose to use charcoal lighting fluid, **ONLY** use charcoal lighting fluid approved for lighting charcoal. Do not use gasoline, kerosene, alcohol or other flammable materials for lighting charcoal. Follow all manufacturer's warnings and instructions regarding the use of their product. Start with 2 to 2.4 pounds (0.9 to 1.1 kg) of charcoal. Place the charcoal in the center of the charcoal grate.

General Operating Instructions

Step3

Saturate charcoal with lighting fluid. With lid open, wait 2 to 3 minutes to allow lighting fluid to soak into charcoal. Store lighting fluid a safe distance from the smoker.

Step4

With smoker lid open, stand back and carefully light charcoal. Allow to burn until covered with a light ash (approximately 20 minutes).

WARNING:

Charcoal lighting fluid must be allowed to completely burn off prior to closing smoker lid (approximately 20 minutes). Failure to do this could trap fumes from charcoal lighting fluid in smoker and may result in a flash-fire or explosion when lid is opened.

Step5

Place cooking grate on smoker body.

WARNING:

Always wear oven mitts / gloves, use lifter (not included) when remove cooking grate and / or charcoal grid to protect your hands from burns.

Step6

Place food on cooking grate and close smoker lid. Always use a meat thermometer to ensure food is fully cooked before removing from smoker.

Step7

Allow smoker to cool completely, and then follow instructions in the "Cleaning and Maintenance " and " Environmental Protection & Disposal " sections of this manual.

General Operating Instructions

WATER SMOKING

Step1

Put the charcoal in the charcoal bowl and light it up, carefully following the instructions on building a fire that are listed on pages 11-13

Step2

Once unit is lit, position water bowl so rim is resting securely on notched out step of all support brackets.

Step3

Carefully, fill water bowl with warm water or marinade to 1" below the rim. A full bowl holds approximate 4 quarts of water and will last for approximately 2-3 hours. Do not overfill or allow water to overflow from water bowl.

Step4

Place a cooking grate on the middle bracket that same level of the water bowl. Like the figure illustrated. 

Step5

Place food on the cooking grate in a single layer with space between each piece. This will allow smoke and moist heat to circulate evenly around all pieces.

Step6

Place other cooking grate on the upper support brackets. Make sure the rim is resting securely on notched out step of all three support brackets. place food on the cooking grate.

Step7

Cover the lid on smoker body.

Step8

Allow food to cook. After 1-3 hours of cooking (depending on temperature), more liquid may be required. Check the level through the access door.

Step9

Always use a meat thermometer to ensure food is fully cooked before removing from smoker.

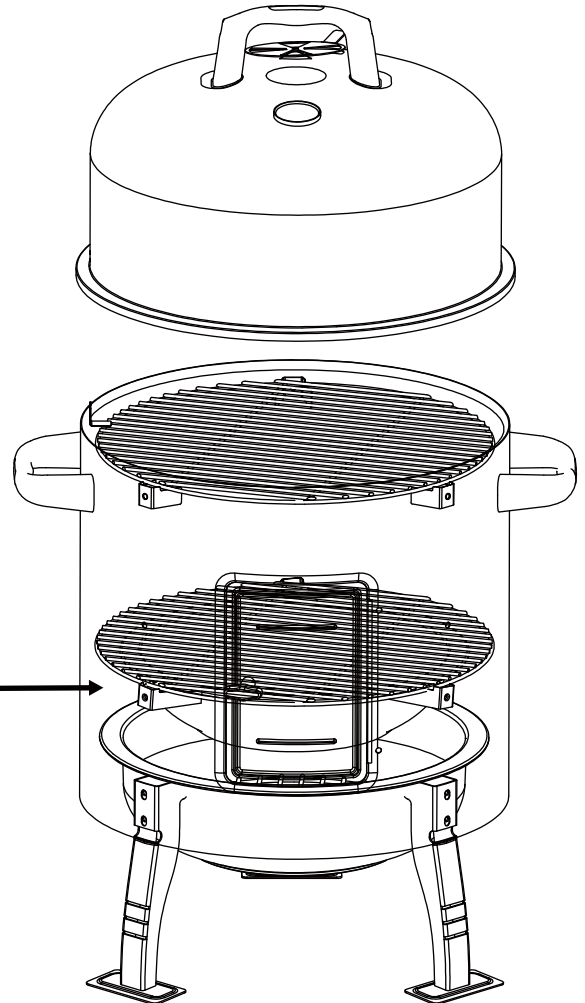

General Operating Instructions

GRILLING

Step1

Remove the cooking grates, water bowl and charcoal bowl with grate. Replace the cooking grate on middle bracket. Make sure the rim is resting securely on notched out step of lowest support brackets.

Step2

Put the charcoal bowl on the charcoal grate on the middle cooking grate.

Step3

Put the charcoal in the charcoal bowl and light it up. If you choose to use charcoal lighting fluid, only use lighting fluid approved for lighting charcoal. Carefully read manufacturer's warnings and instructions on the charcoal lighting fluid and charcoal prior to the use of their product. Store charcoal lighting fluid safely away from grill.

When using charcoal lighting fluid, allow charcoal to burn with grill lid open until covered with a light ash (approximately 20 minutes). This will allow charcoal lighting fluid to burn off.

Failure to do this could trap fumes from charcoal lighting fluid in grill and may result in a flash fire or explosion when lid is opened. We recommend the use of a Charcoal Chimney Starter to avoid the dangers associated with charcoal lighting fluid.

Step4

Place a cooking grate on the top support brackets.

Step5

Place food on the top level cooking grate and start grilling.

Step6

Always use a meat thermometer to ensure food is fully cooked before removing from smoker.

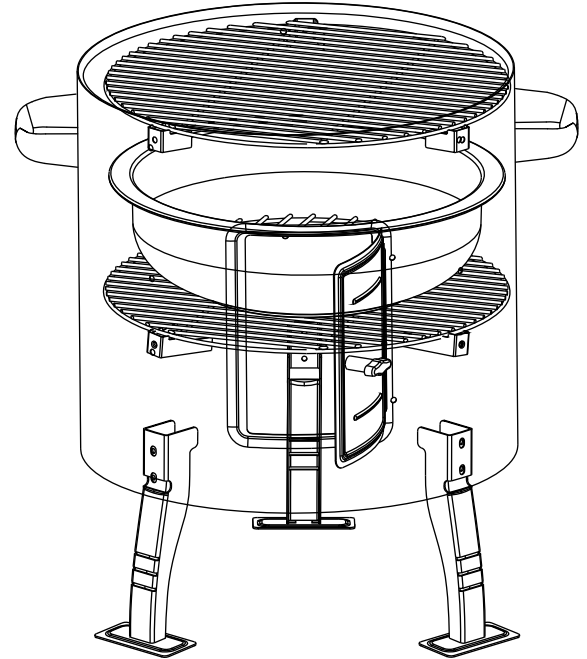

Cleaning and Maintenance

⚠ WARNING:**Risk of burning!**

Allow the smoker to cool down completely before cleaning it.

Never use water to quench the hot smoker. This could result in burning or scalding.

Occasional cleaning is necessary to preserve the beautiful appearance of the smoker. Do not use any scouring agents.

1. A rinsing cloth and some water with a commercial detergent is sufficient for the normal cleaning process.
2. If the enamelled parts are heavily soiled, use a commercial enamel cleaning agent (oven cleaner). Observe the manufacturer's instructions for the cleaning agent being used.
3. Clean the grill using some washing-up liquid and a rust proof cleaning pad.

Environmental Protection & Disposal

Pay attention to cleanliness when using the smoker and dispose of waste in a clean and safe manner. As a general rule, only dispose of waste in designated metal or non-flammable containers. The local regulations for disposal apply.

Warranty

LIMITED WARRANTY

This warranty is a limited warranty, and applies to the original purchase is required. This is a residential warranty and does not apply to commercial use. This collection carries a (1) year limited warranty and is valid from original date of purchase to the original owner (proof of purchase required).

WHAT IS COVERED

We warrant the frame to be free of Manufacturing defects to the original purchaser for one year.

WHAT IS NOT COVERED

This warranty does not cover commercial use, hardware, acts of nature, fire, freezing and abusive.

In addition, purchased parts are not covered under this warranty.

We reserve the right to make substitutions with similar merchandise, if the model in question is no longer in production.

For a copy of our full limited warranty, please contact our customer service team below.